

# XR650L FAIRING INSTALLATION

- APPLY THREADLOCKER TO ALL HARDWARE.
- DO NOT USE POWER TOOLS, TO AVOID RISK OF CLINCH NUT SEPARATION.

1

REMOVE STOCK FAIRING.  
RETAIN MOUNTING  
HARDWARE.

WHEN INSTALLING GROMMETS,  
IF THE FIT IS TIGHT, ADD A DROP  
OF LIQUID CLEANER TO EASE  
INSTALLATION. YOU MAY ALSO  
REUSE YOUR OLD GROMMETS  
IF DESIRED.

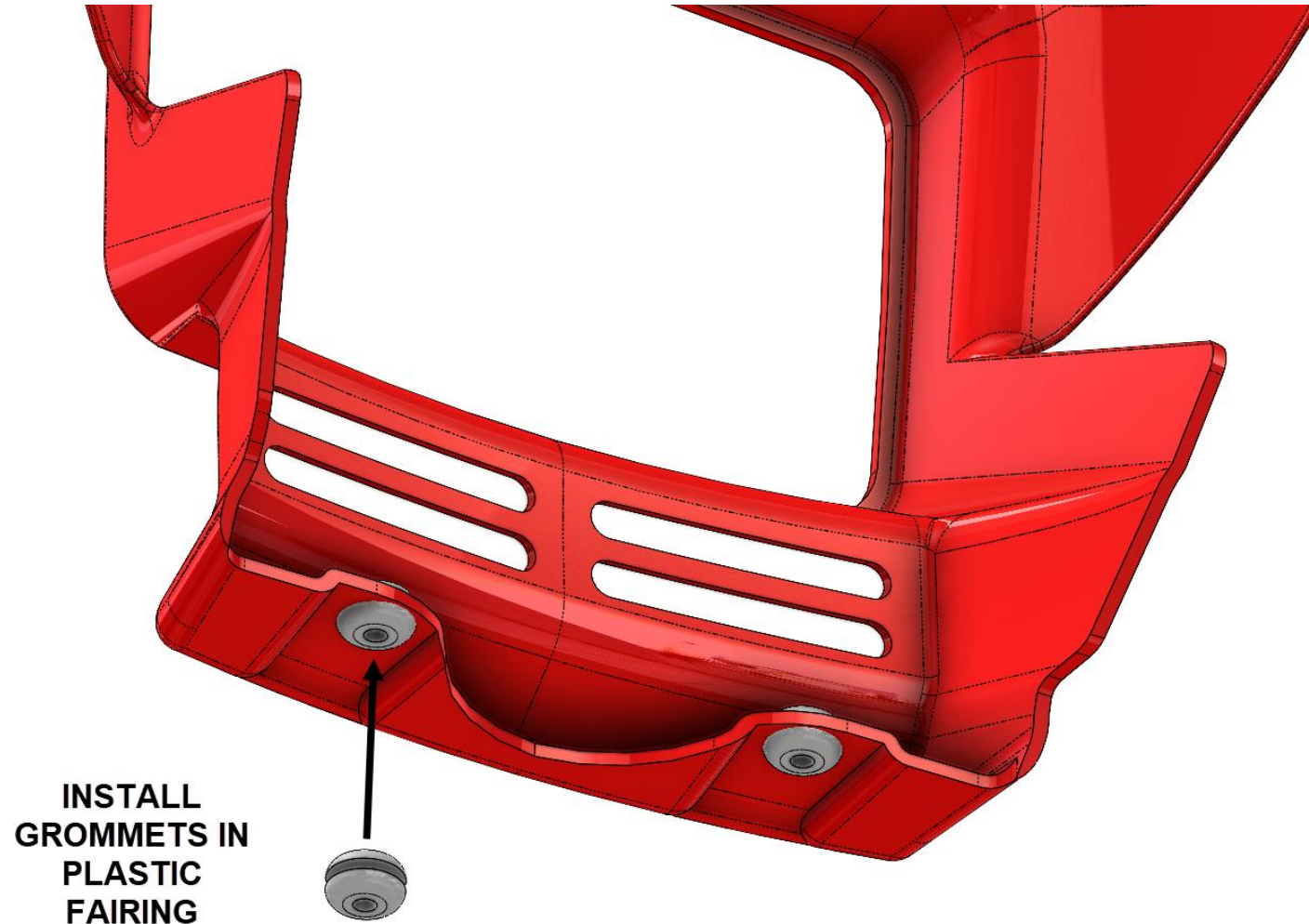

# XR650L FAIRING INSTALLATION

2

INSTALL SCREWS AND NUTS FOR  
LEFT AND RIGHT METAL SUPPORTS.

LEAVE LOOSE.

**IF INSTALLING A WINDSHIELD OR  
AUXILIARY LIGHT MOUNT,  
DISCARD THE M6 NUTS AND  
INSTALL THE SCREWS FROM  
INSIDE THE FAIRING INTO THE  
MOUNTING BRACKETS. SEE  
SEPARATE INSTRUCTIONS.**

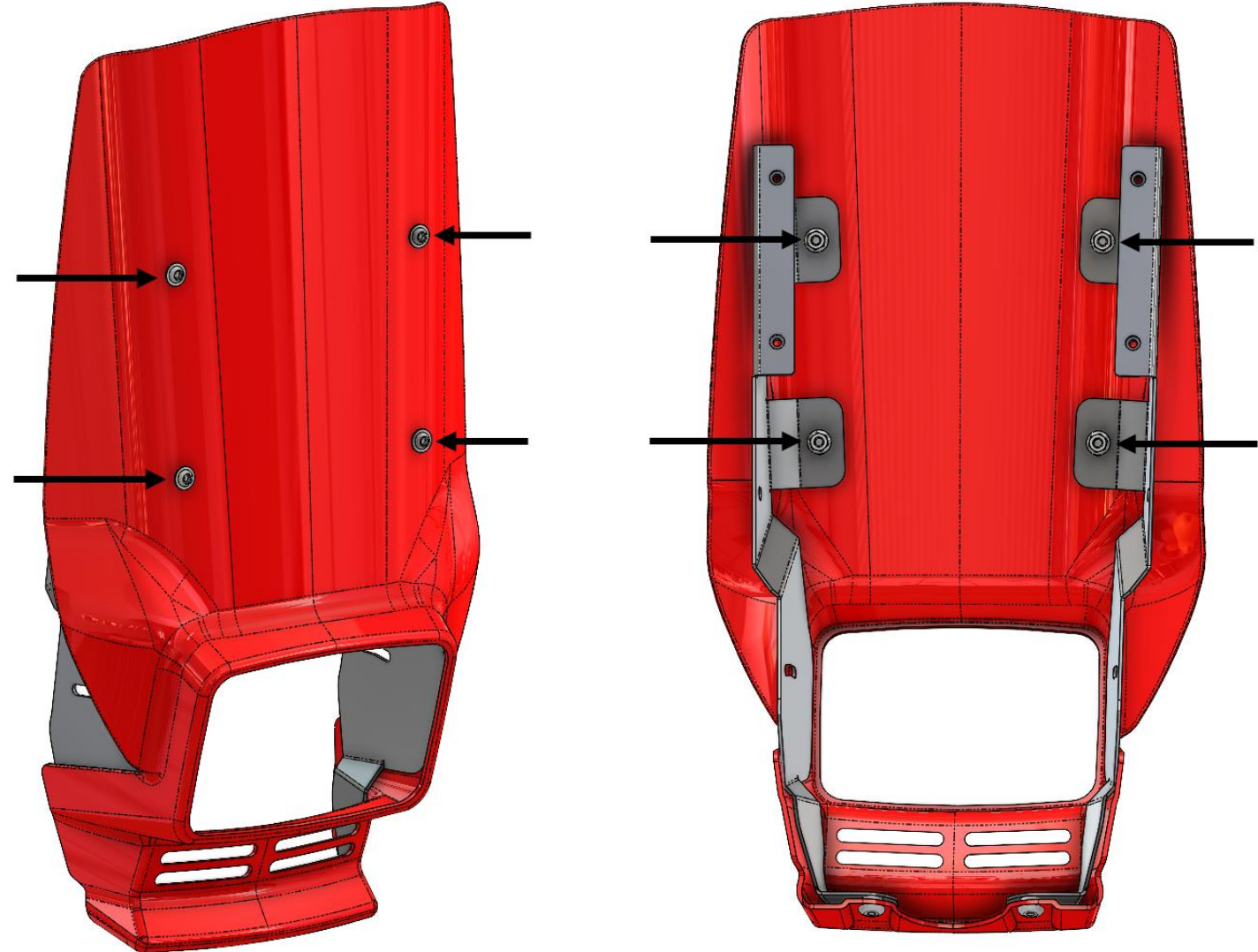

# XR650L FAIRING INSTALLATION

3

REMOVE THE LEFT  
FORK CLAMP BOLTS.  
INSTALL THE SUPPORT  
BRACKET AS SHOWN  
USING THE STOCK  
BOLTS.

LEAVE BOLTS LOOSE.

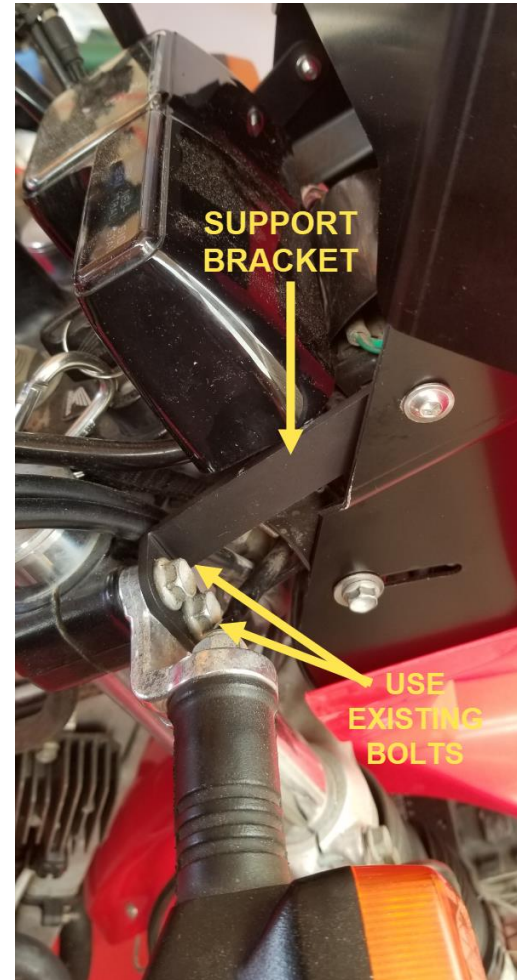
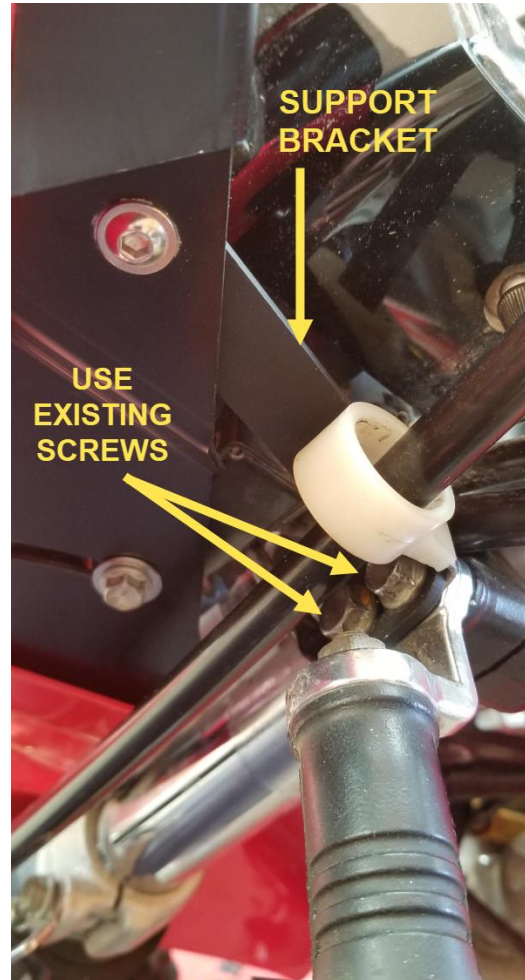

REMOVE THE RIGHT  
FORK CLAMP BOLTS.  
INSTALL THE SUPPORT  
BRACKET AS SHOWN  
USING THE STOCK  
BOLTS.

LEAVE BOLTS LOOSE.

# XR650L FAIRING INSTALLATION

4

INSTALL DASHBOARD  
SCREWS.

LEAVE LOOSE.

INSTALL FAIRING  
ASSEMBLY ONTO THE  
STOCK MOUNTING  
PINS UNDER THE  
HEADLIGHT.

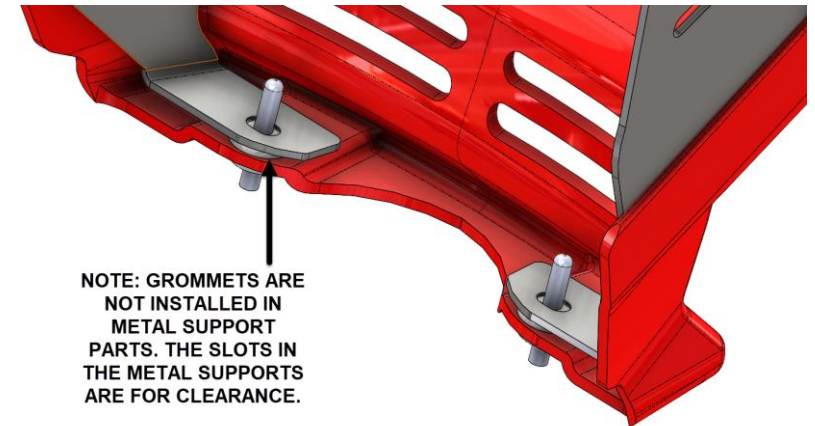
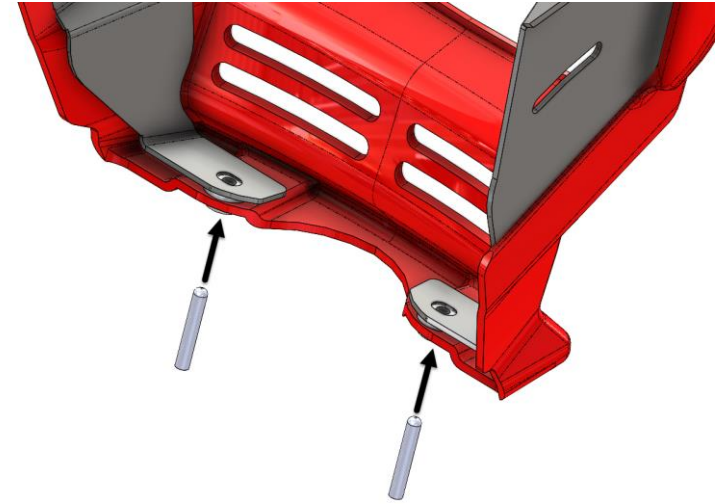
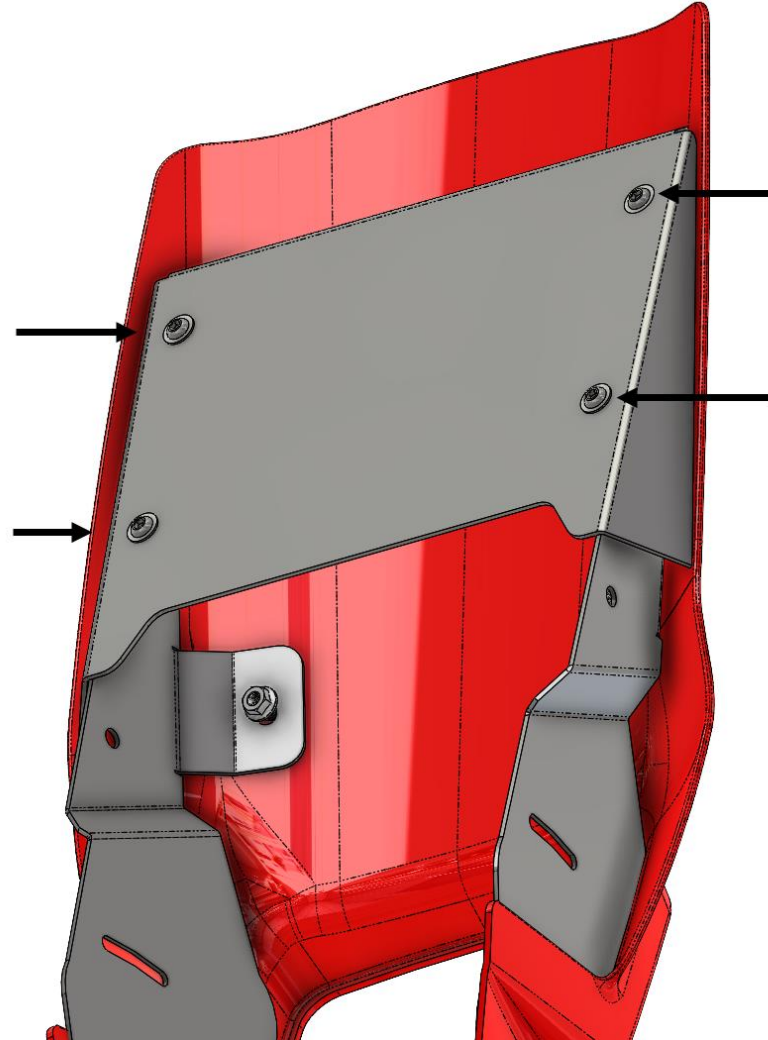

# XR650L FAIRING INSTALLATION

5

LOCATE SMALL SUPPORT BRACKETS TO THE INSIDE OF THE FAIRING SHEET METAL. LOOSELY INSTALL M6 SCREWS FROM THE OUTSIDE.

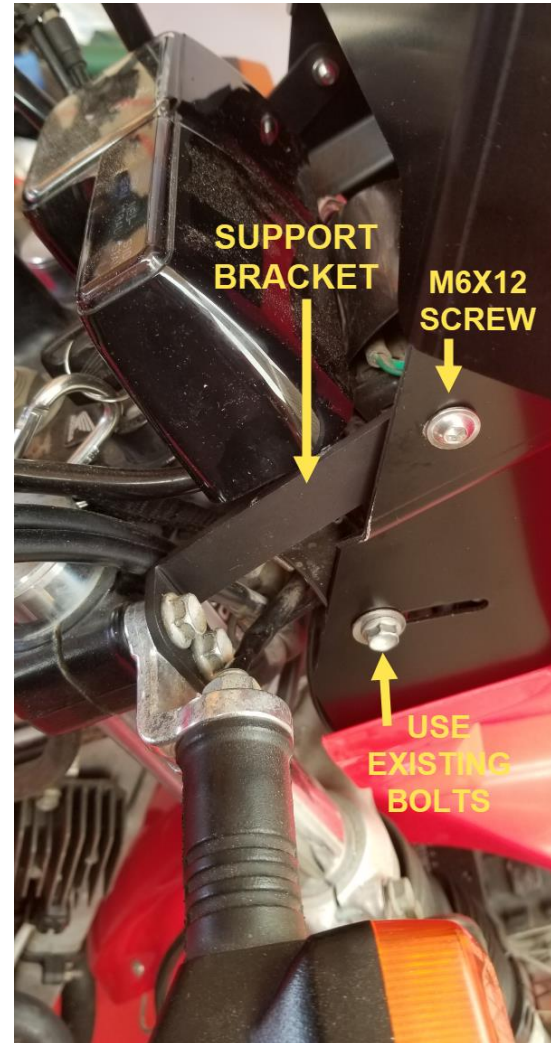

LOOSELY INSTALL THE STOCK MOUNTING BOLTS THROUGH THE CURVED SLOTS, INTO THE FRAME.

THE SLOTS ALLOW SOME ANGLE ADJUSTABILITY BUT YOU MAY NEED TO RE-ROUTE CABLES BEHIND THE DISPLAY HOUSING TO MAKE ROOM.

# XR650L FAIRING INSTALLATION

6

GET EVERYTHING  
ALIGNED AND IN  
THE POSITION YOU  
WANT.

START TIGHTENING  
THE HARDWARE IN  
NOTED ORDER

